

FILL-RITE

Owner's Manual

SERIES FR400 DIAPHRAGM PUMP

For Industrial Fluid Transfer

For models:
FR405, FR410, FR412, FR205, FR210, FR212 (DC)
& FR450, FR450E, FR452 (AC)

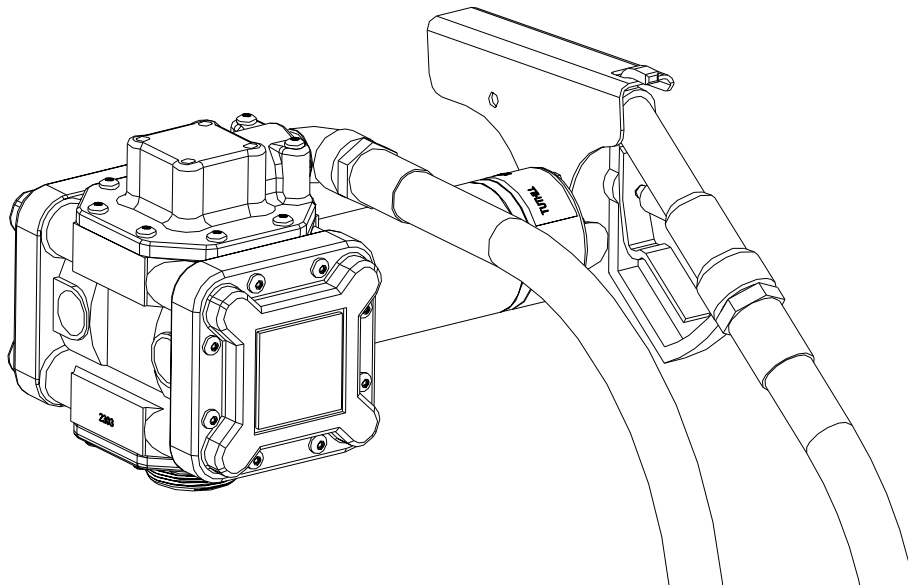

Model FR410

Patent #5,219,274

 **DANGER**



EXPLOSION PROOF MOTOR
 OPTION: Electrical wiring should be done by a licensed electrician in accordance with approved electrical codes. Motor should be properly grounded and a rigid conduit should be used when installing electrical wiring. Improper use or installation of this product can cause serious bodily injury or death.

 **DANGER**

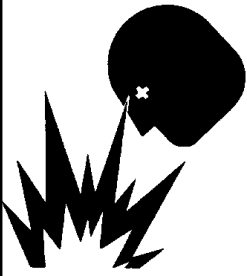

Not for use with fluids that have a flash point below 100°F (37.8°C, ie: gasoline, alcohol). Refer to NFPA 325M (Fire Hazard Properties of Flammable Liquids, Gases, and Volatile Solids) for flash points of common liquids. Static electricity buildup and discharge could result in arc and explosion.

 **SAFETY INSTRUCTIONS**

1. Use Teflon® tape to seal all joints to avoid leakage of fluids being pumped. Leaking of caustic and/or hazardous fluids could result in severe injuries.
2. **Never disassemble YOKE ASSEMBLY (see item 12). This is under extreme pressure and injury could result.**
3. Tank or barrel should be anchored to prevent tipping in both the full and empty conditions.
4. The pump motor is equipped with thermal overload protection. If overheated, it will shut itself off without any damage to the windings. Be sure to turn off the pump power if this occurs. As the motor cools, it will start without warning if power is on.

 **WARNING**

This pump should not be used to fuel aircraft. This pump is not suited for use with fluids for human consumption.

GENERAL DESCRIPTION

The Fill-Rite Series FR400 is a double action diaphragm pump, using a patented, spring-driven, positive displacement mechanism. The flow rate with low viscosity material is up to 13 GPM/49 LPM. The ultimate in chemical handling capability is provided with stainless steel, polypropylene, polyester and fluorocarbon wetted parts.

OPTIONS

- 1" polypropylene ball valve/nozzle
- Buna-N or EPDM hose
- Telescoping steel suction tube
- 820 electronic digital meter (for thin or thick viscosities)
- 2" NPT or 2" buttress inlet bung adapter
- 1" FNPT straight and 90° inlet/outlet fittings available
- Wraparound tubular mounting frame
- Santoprene diaphragms
- 12 VDC, 24 VDC, 115 VAC/60 Hz, 230 VAC/50 Hz available

TECHNICAL INFORMATION

Design Features

- 1" FNPT straight inlet and 90° outlet standard
- 15 PSIG maximum outlet pressure
- 2600 RPM, 1/4 HP motor:
 - 12 VDC, rated at 20 amps
 - 24 VDC, rated at 10amps
 - 115 VAC/60 Hz rated at 2.0 amps
 - 230 VAC/50 Hz rated at 1.1 amps
- Thermal overload protection of the motor
- Positive displacement/self-priming design
- Unaffected by particulate materials up to 0.100" diameter in the pumped fluids
- Flow easily controlled by outlet throttling from maximum to zero
- Pump may run dry without damage
- Handles viscosities from 1.0 CPS to 3000 CPS (SAE 140 gear oil at 68°F)
- Minimum shear (agitation) of pumped fluids
- Does not include inlet strainer
- Minimum operating temperature: -10°F (-23°C)
- Maximum operating temperature: 130°F (54°C)
- Overall dimensions: 14" (35.6 cm) long x 8.25" (21cm) high x 8.75" (22.2 cm) deep
- 30 minute duty cycle, not for continuous operation

Fluid Compatibility

The FR400 Series pump is compatible with the following fluids:

- Ethylene Glycol, Hydraulic Oil, Motor Oil, Water

The FR400 Series pump is **NOT** compatible with the following fluids:

- Strong Acids (Hydrochloric Acid, Sulfuric Acid)
- Any material with Flash Point under 100°F.

If in doubt about compatibility of a specific fluid, contact the supplier of the fluid to check for any adverse reactions to the wetted materials.

Fluorocarbon	Polypropylene
FilCon™	Stainless Steel
Buna-N	

INSTALLATION

The basic pump is furnished with 1" NPT threaded openings in the inlet and outlet flanges. Flanges are available as a straight outlet or a 90° angle design, which can be rotated four ways to accommodate different installation needs. Both inlet and outlet flanges include four 1/4-20 threaded holes, spaced 1 7/8" between centers, for secure mounting.

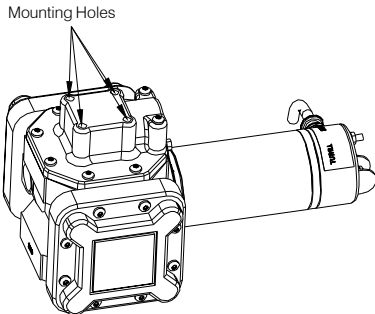

Adapters are available to fit the pump to a 2" bung and a selection of standard bung fittings common in the petroleum, chemical and agricultural markets. Use pipe compound or Teflon® tape on all threaded fittings (except 2" bung threads if present).

Electrical Installation

	DANGER
	<p>EXPLOSION PROOF MOTOR OPTION: Electrical wiring should be done by a licensed electrician in accordance with approved electrical codes. Motor should be properly grounded and a rigid conduit should be used when installing electrical wiring. Improper use or installation of this product can cause serious bodily injury or death.</p>

DC ONLY: Connect cable to 12 volt DC power supply as follows, paying special attention to wire colors:

Pump	Cable
Positive	Red
Negative	Black

If pump is to be mounted on a vehicle, it is recommended that permanent wiring and connections be made to vehicle power system which includes a 30 amp slow blow fuse.

	DANGER
	<p>Not for use with fluids that have a flash point below 100°F (37.8°C, ie: gasoline, alcohol). Refer to NFPA 325M (Fire Hazard Properties of Flammable Liquids, Gases, and Volatile Solids) for flash points of common liquids. Static electricity buildup and discharge could result in arc and explosion.</p>

Circuit Breakers (AC only)

Power to the unit should be supplied from a dedicated circuit breaker. No other equipment should be powered from this breaker. Provision must be made to break both legs of any AC circuit.

Dimensions

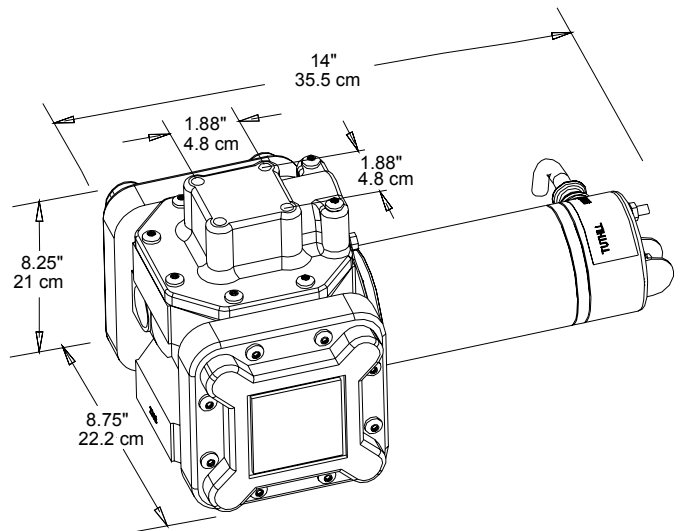

CALIBRATION

If a meter is used, calibrate according to the instructions in the meter's Owner's Operation & Safety Manual.

ASSEMBLY/DISASSEMBLY

NOTE: Pump should be thoroughly flushed prior to disassembly.

Motor/Gear Assembly Removal (Refer to exploded view of pump)

1. If possible, position pump with sight caps (item 30) down.
2. Remove four screws (item 20) and lift out motor/gear assembly (item 1 and 24).
3. Drain oil from pump if additional maintenance to pump is required.

Gear Assembly Replacement

1. Remove six screws (item 25) and pull gear assembly (item 24) from motor.
2. Pull drive gear (item 27) and key (item 28) from motor shaft.

DO NOT DISASSEMBLE GEAR ASSEMBLY. Planet gears and ring gear are marked for proper assembly and must not be altered.

Diaphragm Assembly/ Check Valve Replacement

NOTE: Diaphragm and check valve assemblies can be serviced without removing oil from pump body by removing one at a time with diaphragm facing up. Care must be taken not to contaminate oil.

1. Loosen cover (item 4) screws (item 20) slightly and drain fluid trapped in the pumping chamber. Then remove screws and covers.
2. Remove retainer screws (item 11) and o-rings (item 42).
3. Remove diaphragm assemblies (items 7, 8, 9 and 10) by pulling check valves out of pump body, starting with outlet valves first (item 9 at top of pump).
4. Install new diaphragm/check valve assembly, noting ball location in relation to flow. O-rings are on inlet valves at bottom of pump. Lubricate O-rings before inserting into pump body. See Figure #1.

Figure #1

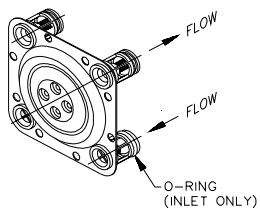

5. Insert four screws (item 11) and o-rings (item 42) into diaphragm as shown and tighten to 35 in. lbs. of torque.
6. Install pump covers (item 4). Hand start and tighten torx head screws (item 19) to 75 in. lbs.

To further disassemble pump, after step #3 above.

7. Remove motor and drain oil, if complete disassembly is required.
8. Remove four screws (item 19) holding bearing plate (item 17).
9. Remove bearing plate (item 17) and thrust plate (item 16).
10. Remove drive shaft (item 13), bearing (item 14), bearing ring (15) and yoke assembly (item 12).

Never disassemble YOKE ASSEMBLY. This is under extreme pressure and injury could result.

Assemble in reverse order. Hand start and tighten torx head screws to 75 in. lbs.

MAINTENANCE

To keep pump running at its best, periodically perform the following procedures. (Refer to exploded view drawing of pump)

Chemical Applications

Do not allow chemical to remain in the pump for any extended period of time, whereby the chemicals are allowed to "dry out." Thoroughly rinse pump and meter by flushing the pump with water or appropriate flushing fluid.

DO NOT USE PRESSURIZED WATER OR PRESSURIZED AIR to flush your pump. Damage to the equipment can occur if flush water pressure exceeds 15psi (1 bar). Instead, submerge the suction tube or inlet adapter in clean water and dispense water by operating the pump. Dispose of the flush water properly. After flushing, pump air to remove as much water as possible.

All Applications on annual basis or as needed.

1. Tighten all external torx head screws to 75 in. lbs. (items 19 & 23).

NOTE: NEVER EXCEED 50 IN. LB. TORQUE WHEN TIGHTENING PHILLIPS OR HEX SCREWS.

2. Drain oil through sight caps and replace oil with approximately 16 ounces of automotive grade SAE 30W through one of the sight cap holes. The oil level should be level with the bottom edge of the sight caps (item 30) located on the front of the pump body.

NOTE: Always check oil level when the pump is *level*.

NOTE: If external torx head screws (items 19 & 23) are removed, hand start and tighten to 75 in. lbs. Tighten motor flange phillips or hex head screws to 50 in lbs.

REPAIR

Pumps being returned for service must be triple-rinsed and accompanied by an MSDS sheet indicating the chemicals/fluids which have been pumped. Pumps not adhering to these specifications may be refused service at either the repair shop or the factory.

Performance

- Maximum of 30 minute duty cycle, not for continuous operation
- 9 inches of mercury dry vacuum
- Suction lift: 10' for water. The lift in feet is equivalent to the vertical distance from the surface of the fluid in the tank to the inlet of the pump, PLUS the friction losses through the vertical and horizontal runs of pipe, all elbows and other fittings. Systems should be designed to require a minimum amount of suction lift.

SERIES 400 DIAPHRAGM PUMP TYPICAL FLOW RATE FOR VARIOUS VISCOSITIES

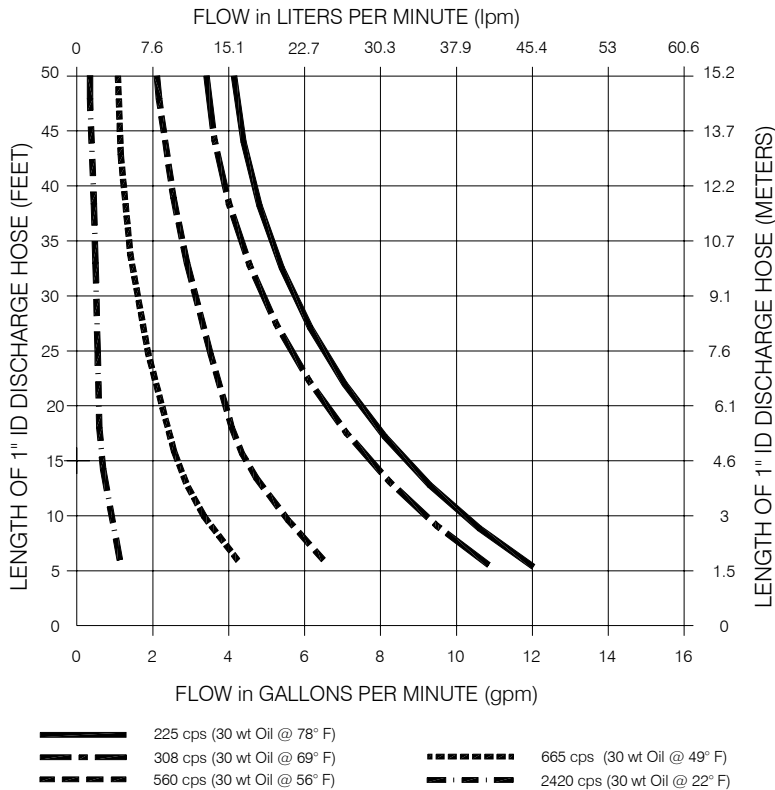

NOTES:

- SUCTION LOSSES.**
Test pump was mounted on a 55 gallon drum of oil, 1/2 full. A FILL-RITE 1" suction pipe was used.
A longer or smaller diameter inlet pipe will lower the flow rate.
- VERTICAL HEAD LOSSES.**
Test hose was horizontal with pump. Add 3 feet of hose for each 1 foot of vertical rise.
- OTHER LOSSES.**
Elbows, quick-disconnects, swivels, and check valves in outlet or inlet hoses will restrict the flow.
Add the estimated length of hose for each component used.

Other 1" disconnects + 13.0 feet
1" Check Valves + 8.7 feet
1" Elbow + 2.6 feet

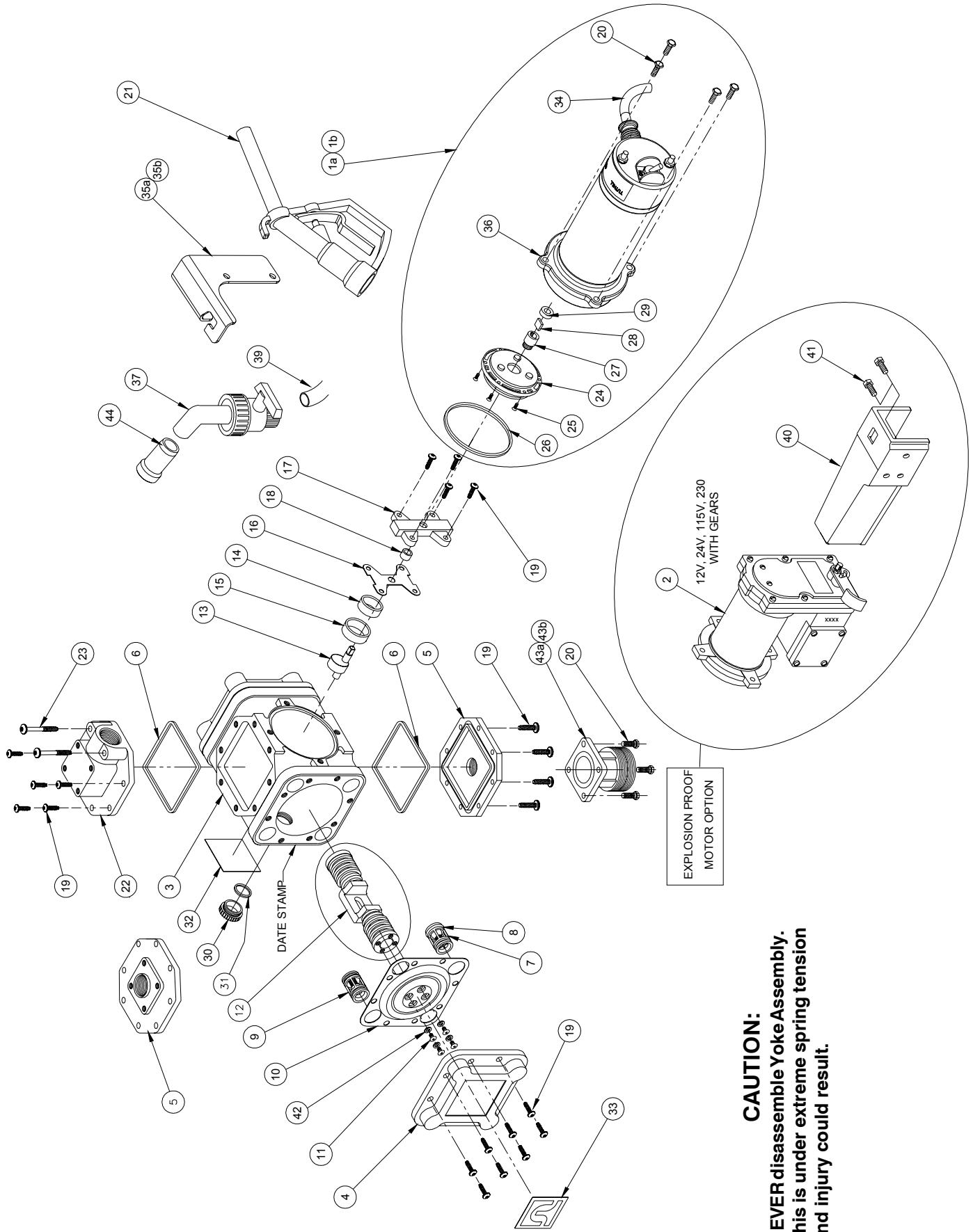

CAUTION:
NEVER disassemble Yoke Assembly.
 This is under extreme spring tension
 and injury could result.

SERIES 400 PUMP PARTS LIST

ITM. NO.	PART NO.	DESCRIPTION	QTY.
1a	400G9734	12 VDC Motor with gears	Opt.
1b	400G9735	115 VAC 60 Hz Motor with gears	Opt.
2a	400EXPF6846	Motor Assembly - 12 VDC EXP PROOF	Opt.
2b	200EXPG7738	Motor Assembly - 24 VDC EXP PROOF	Opt.
2c	400EXPF7351	Motor Assembly - 115 VAC EXP PROOF	Opt.
2d	400EXPG7186	Motor Assembly - 230 VAC EXP PROOF	Opt.
3	400G9822	Pump Body	1
4	400F6568	Pump Cover	2
5	400F6569	Flange, straight	1
6	400F6924	Gasket Inlet Flange	2
7	400F6571	Check Valve - Inlet	4
8	35F6588	O-ring (-117) (Included w/Item 7)	4
9	400F6589	Check Valve - Outlet	4
10	400F7238	Diaphragm Assembly - FilCon™ (Includes Items 7, 8, 9)	2
	400F6917	Diaphragm Assembly - Santoprene™ (Includes Items 7, 8, 9)	Opt.
11	400F6795	#10-24 x 1/2 THMS	8
12	400F6781	Yoke Assembly	1
13	400F6800	Drive Shaft	1
14	400F6819	Eccentric Bushing	1
15	400F6827	Bearing Ring	1
16	400F6880	Thrust Plate	1
17	400F6579	Bearing Plate	1
18	400F6693	Shaft Bushing	2
19	400G9685	1/4 x 1" PTS screw, SS	34
20	400F0267	1/4-20 x 3/4 PHMS	8
21	6U100	Nozzle, Aluminum	1
22	400F6679	90° Flange with brass inserts	1
23	400G9687	1/4 x 2.3" PTS screw, SS	2
24	400F6557	Gear Assembly (Included w/Item 1 or 2)	1
25	400G7494	#6-32 x 1/2 FHMS (Incl. w/Item 1 or 2)	6
26	400F6692	Gasket Motor Flange	1
27	400F6563	Drive Gear (Included w/Item 1 or 2)	1
28	1200F6440	Drive Key (Included w/Item 1 or 2)	1
29	400G9104	Shaft Seal (Included w/Item 1 or 2)	1
30	400F6818	Sight Cap, Polypropylene	2
31	400F6813	O-ring (-022)	2
32	400F8517	Nameplate	1
33	400F6758	Logo Plate	2
34	1200F7207	Cable 20 feet (DC Only)	20 FT
35a	400G9736	Nozzle Holder, Aluminum Nozzle	Opt.
35b	400G9737	Nozzle Holder, Poly Nozzle	Opt.
36	400F6566	Gear Housing (Included w/Item 1 or 2)	1
37	400G7006	Ball Valve Nozzle, 1", Poly Nozzle	Opt.
39	700F3123	1" x 12' EPDM Hose	Opt.
	400F3140	1" x 12' Polyethylene lined Hose	Opt.
40	700F6748	Nozzle Cover (Explosive Proof motor)	Opt.
41	600F2220	5/16-18 x 3/4 HHCS	Opt.
42	400G8887	O-Ring (007)	8
43a	400G9140	Bung Adapter - NPT	Opt.
43b	400F6528	Bung Adapter - Buttress	Opt.
44	400KTF0237	Anti-Drip Spout	Opt.
	400F7320	Power Cord (115 VAC Only) (Not Shown)	Opt.
	650G7185	Power Cord (230 VAC Only) (Not Shown)	Opt.
	400F1855	Suction Pipe, Polypropylene (Not Shown)	Opt.
	400F1855	Suction Pipe, Polypropylene (Not Shown)	Opt.

WHEN ORDERING REPAIR PARTS, BE SURE TO GIVE REPLACEMENT PART NUMBER, DATE OF MANUFACTURE AND PUMP MODEL NUMBER. THIS WILL ENSURE THAT THE CORRECT REPLACEMENT PART IS SUPPLIED.

400KTF6862	Series, 400 Repair Kit (Includes Items 6-11, 24-28, & 42)
------------	--

TROUBLESHOOTING GUIDE

PROBLEM	POSSIBLE CAUSE	SOLUTION
Pump won't prime	<ul style="list-style-type: none"> • Suction line problem • Leaky check valves • Check valves improperly installed • Outlet plugged • Motor not operating • Stripped or damaged gears 	<ul style="list-style-type: none"> • Check for leaks in suction line. • Check for dirt or damaged check valves and replace. • Check for proper installation. • Check for blockage and clear. • Check power source. • Repair or replace motor. • Check gear assembly and drive gear for damage. Replace complete assembly if necessary.
Pump hums but will not operate	<ul style="list-style-type: none"> • Motor faulty • Gear mechanism jammed 	<ul style="list-style-type: none"> • Replace motor. • Check for free rotation of the gears.
Low pump capacity	<ul style="list-style-type: none"> • Low voltage • Leaky suction line • Dirt in check valves • Faulty check valves • One or both diaphragms leaking • One piston screw loose • Piston retainer screws loose • Debris ingested 	<ul style="list-style-type: none"> • Check power source. • Repair leaks. • Dismantle and clean. • Install repair kit. • Install repair kit. • Install new yoke assembly. • Install new yoke assembly. • Add inlet screen.
Motor overheats	<ul style="list-style-type: none"> • Pumping hot fluids • Motor faulty 	<ul style="list-style-type: none"> • Shorten duty cycle. • Replace motor.
Fluid leakage	<ul style="list-style-type: none"> • Faulty or missing gaskets • Loose bolts • Cracked component • Piston retainer screws loose 	<ul style="list-style-type: none"> • Install all gaskets specified in parts list. • Torque all torx head bolts to 75 in. lbs. • Torque all external phillips or hex head 1/4-20 bolts to 50 in. lbs. • Replace defective component. • Install new yoke assembly.

NOTES

FILL-RITE®

PRODUCT WARRANTY

Tuthill Transfer Systems ("Manufacturer") warrants to each consumer buyer of its Fill-Rite products (the "Buyer"), from the date of invoice or sales receipt, that goods of its manufacture ("Goods") will be free from defects of material and workmanship. Duration of this warranty is as follows:

- Heavy Duty Products - Two years
- Standard Duty Products – One year
- Economy Duty Products – One year
- Cabinet pumps, Parts, and Accessories - One year

Manufacturer's sole obligation under the foregoing warranties will be limited to either, at Manufacturers' option, replacing or repairing defective Goods (subject to limitations hereinafter provided) or refunding the purchase price for such Goods theretofore paid by the Buyer, and Buyer's exclusive remedy for breach of any such warranties will be enforcement of such obligations of Manufacturer. If Manufacturer so requests the return of the Goods, the Goods will be redelivered to Manufacturer in accordance with Manufacturer's

instructions F.O.B. Factory. The remedies contained herein shall constitute the sole recourse of the Buyer against Manufacturer for breach of warranty. IN NO EVENT SHALL MANUFACTURER'S LIABILITY ON ANY CLAIM FOR DAMAGES ARISING OUT OF THE MANUFACTURE, SALE, DELIVERY, OR USE OF THE GOODS EXCEED THE PURCHASE PRICE OF THE GOODS. The foregoing warranties will not extend to Goods subjected to misuse, neglect, accident or improper installation or maintenance, or which have been altered or repaired by anyone other than Manufacturer or its authorized representative. THE FOREGOING WARRANTIES ARE EXCLUSIVE AND IN LIEU OF ALL OTHER WARRANTIES OF MERCHANTABILITY, FITNESS FOR PURPOSE OF ANY OTHER TYPE, WHETHER EXPRESS OR IMPLIED. No person may vary the foregoing warranties and remedies except in writing signed by a duly authorized officer of Manufacturer. Warranties or remedies that differ from the foregoing shall not otherwise be binding on Manufacturer. The Buyer's acceptance of delivery of the Goods constitutes acceptance of the foregoing warranties and remedies, and all conditions and limitations thereof.

